

## New Mazor-AU (Touch Screen) Fully Automatic Medical Gas Manifold

The New Mazor-AU fully automatic changeover system is designed to meet the NFPA99, or EN ISO 7396-1, or HTM02-01 or G-01 standard.

The system manages 2 sources and provides continuous supply and smooth automatic bank switchover by means of pneumatic shuttle valve.

All medical gas information is displayed graphically and digitally on a 12" full HD LCD touch screen.



### Features & Benefits

- Continuous supply and smooth automatic bank switchover, without pressure fluctuation, by means of pneumatic shuttle valve.
- Maintenance friendly- designed to enable maintenance during operation without the need to disrupt the gas supply.
- LCD 12" touch screen display.
- Graphically & digitally display of the actual status of each source- "In use" or "Stand by".
- Visual & audio alarm signals in case of change between banks, "Below min" and High/Low line supply pressure.
- Leak detection from manifolds on Stand-By mode.
- Secured Ethernet based network communication between all units.
- Unique secured authentication of each unit to avoid fake/masking of alarms.
- Flow & Consumption - Monitors & displays flow rate and consumption of the medical gas\*.
- A color trend arc showing the gas pressure status on the main line and at each bank
- Optional- display of heaters during idle and active states.
- Automatic adjustment of screen brightness (day & night mode).
- Event logging, recording all alarms and panel activities.
- Periodical maintenance alert.
- Customizable text & language.
- Alarm test & mute buzzer buttons.
- Advanced Communication:
  - Ethernet Modbus
  - Remote monitoring through building management system available.
  - Option for remote viewing through mobile device or remote computer.

### Silbermann's Quality Management System:

- EN ISO 13485-2016
- ISO 9001-2015

CE  
0123



\* Available according to customer's request.

# Mazor-AU Fully Automatic Medical Gas Manifold

## Medical Gas Pipeline



### Specifications

- Display: 12" HD LCD touch screen
- Cabinet with door:
  - Material - Galvanized steel
  - Dimensions – 60x100x25 cm
  - Finish – Baked on powder coated
- Piping System: All materials are oxygen compatible and cleaned for oxygen use.
- Changeover Unit: Pneumatic.
- Flow Capacity (4 Bar): 90 m<sup>3</sup>/hr.
- Power Supply: 110-220V, 60-50Hz.
- Each cylinder station includes a HP valve, pig tail with integrated NRV and a secure chain.
- Electrical power supply unit installed on the external side of the cabinet. The unit enables automatic connection of 3 supplies:
  - Supply from the mains
  - Supply from the UPS net
  - Supply from batteries (Optional)
- Output connections for local alarms: Two sets of dry contacts NO/NC.
- Optional:
  - Heaters (for N<sub>2</sub>O or CO<sub>2</sub>).
  - Bank heavy duty high pressure filters.



### Dimensions (mm)

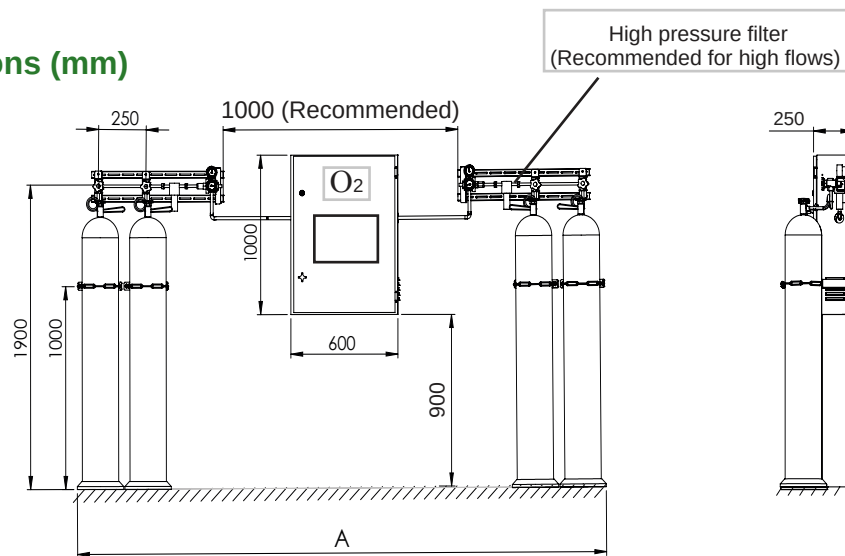

Number of Cylinders*	Min Overall Length-A [meter]**
2X1	1.7
2X2	2.2
2X3	2.7
2X4	3.2
2X5	3.7
2X6	4.2
2X8	5.2
2X10	6.2
2X12	7.2

\* Cylinders aren't included. Additional number of configuration available.

\*\* Overall length without high pressure filters or heaters installation.

With installation of high pressure filters or heaters from both sides, add 0.3 meter to the overall length (A) in the table.

#### NOTES:

1. When ordering:
  - Indicate the required type of gas and pigtail connections. Otherwise CGA connections shall be supplied.
  - Indicate the required MGPS Std (NFPA99/ ISO7396/ HTM 02-01/ G0-1)
2. The system is supplied with a line safety valve.

Distributed By: