

Medical Gas Main Alarm Panel

This colorful 12" touch screen main alarm panel monitors and displays the medical gas source equipment information as required by the latest additions of NFPA99, EN ISO 7396-1 and HTM02-01.

The new Silbermann touch screen main alarm panel incorporates state of the art Hi security technology, protecting the information displayed and transmitted, from malicious attacks.



Features

- LCD 12" touch screen display.
- Display of up to **62** alarms on screen.
- Aesthetics & smooth design without buttons for infection control.
- Secured Ethernet based network communication between all units.
- Unique secured authentication of each unit to avoid fake/masking of alarms.
- Automatic adjustment of screen brightness (day & night mode).
- Self diagnostics with error display for problem identification.
- Event logging, recording all alarms and panel activities.
- Periodical maintenance alert.
- Customizable text & language for alarms text.
- Adjustable alert display- No vacant fields regardless to the No. of alerts.
- Adjustable alert display- managing the alarm display for alerts that require high priority.
- Adjustable digital alarms color (Red/ Yellow).
- Enable/ Disable of digital alarm.
- Adjustable digital alarm type (NO/ NC).
- Automatic adjustment of screen brightness (day & night mode).
- Remote monitoring dry contacts of gas pressure alarm condition including:
High & Low alert,
Below Min alert,
Any Alarm.
- Hinged panel opening for easy installation and maintenance.
- Built-In relay for remote annunciator applications.
- Advanced Communication:
 - Remote viewing through mobile device or remote computer.
 - Wifi communication available.
 - Remote monitoring (Via TCP/IP ModBus) through building management system available.
 - Remote monitoring dry contacts of High and Low gas pressure alarm condition.

Applicable Standards

- Medical Gas Systems: NFPA99, EN ISO 7396-1 & HTM02-01 requirements.



Specifications

- The digital 12" touch screen main alarm system shall be of Silbermann's type.
- Alarm Panel shall be capable of accommodating up to 62 dry contacts. The sensors shall be capable of local or remote mounting.
- Customizable text & language.
- Alarm test & Mute touch buttons shall be easily accessed for operating and testing the unit.
- Adjustable repeat alarm (15 min or OFF. Also 15 seconds for convenient maintenance).
- Alarm buzzer level adjustable : 70,80,90 dB
- Adjustable alarm color for each signal (Red or Yellow)
- Input power shall be 100VAC to 230VAC, 50÷60Hz
- Optional backup battery.



Dimensions [mm]

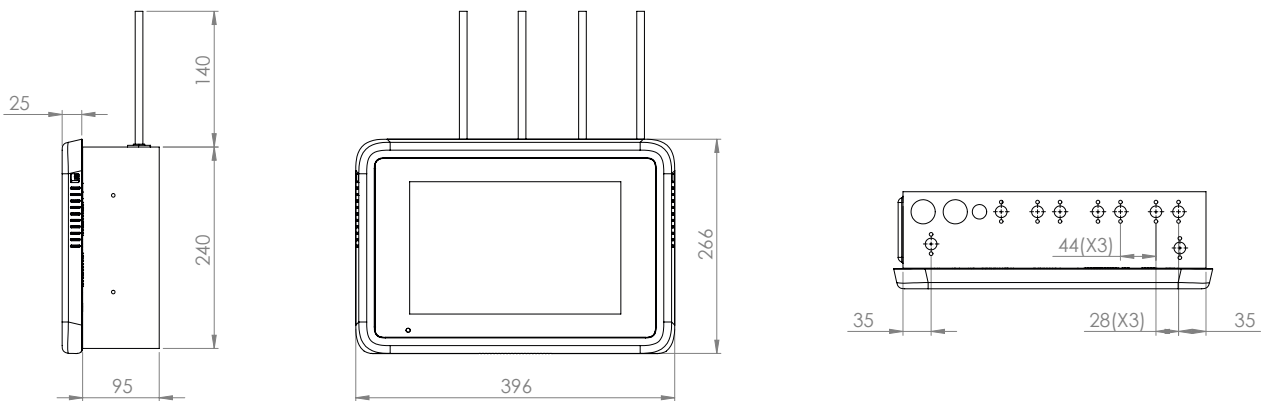

Catalogue Numbers

No. of Alarms	Cat No.
up to 8	7182524
up to 16	7182516
up to 24	7182521
up to 32	7182534
up to 40	7182535
up to 48	7182536
up to 56	7182537

Distributed By: